

1 Allée des Bouleaux -F-95110 SANNOIS
 +33 (0)1 39 98 55 00
 info@restagraf.com

JOINT ALUMINIUM PLAT Ø 14 x 20 x 1.5 mm

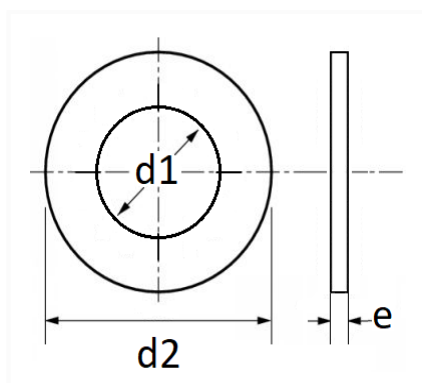

Code article	Nb de références	Nb de pièces	Conditionnement
7659	1	10	SACHET



Informations techniques	
d1	14 mm
d2	20 mm
e	1.5 mm

Matières

ALUMINIUM

Correspondances constructeurs*

FIAT	71741743	FORD Finis	3600377
------	----------	------------	---------

Correspondances constructeurs*			
HYUNDAI	K995641400	KIA	K995641400
MAZDA	995641400	NISSAN	111404A00D
OPEL (GM) N° Catalogue	4708898	OPEL (GM) N° de Pièce	93193729
OPEL (GM) N° de Pièce	94536092	PORSCHE	PAF013849
SUZUKI	0916814012	SUZUKI	0916814015
SUZUKI	09168M14015	SUZUKI	0918814015
VOLKSWAGEN	N0138493	VOLKSWAGEN	N0138494
VOLKSWAGEN	N0138495	VOLKSWAGEN	N0138498

* Informations non contractuelles données à titre indicatif