

1 Allée des Bouleaux -F-95110 SANNOIS
 +33 (0)1 39 98 55 00
 info@restagraf.com

MINI-FLACHSICHERUNG 32V 3A

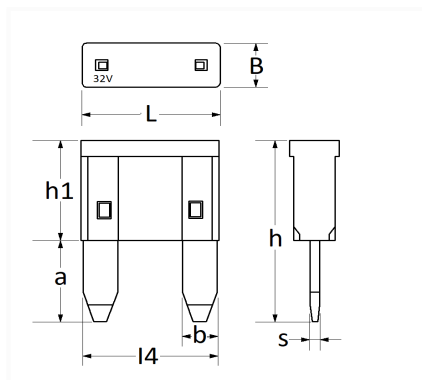

Item code	Number of References	Number of pieces	Conditioning
226849	1	5	BLISTER
6849	1	10	BEUTEL
306849	1	50	BEHÄLTER



Technical informations		
L		11.1 mm
B		3.9 mm
h		16.2 mm
h1		8.9 mm
a		7.3 mm
b		2.8 mm
l4		10.8 mm
s		0.82 mm
Intens.		3 A

Materials
ZINK

Manufacturer correspondence*			
FORD Finis	4418456	FORD Werksnummer	1L3T14A094BA

Manufacturer correspondence*			
IVECO	16710090	MERCEDES-BENZ	A4539820099
NISSAN	24319C9903	OPEL (GM) Katalognummer	1238388
OPEL (GM) Teilenummer	93189656	OPEL (GM) Teilenummer	93189657
PEUGEOT / CITROËN	9666814780	RENAULT	7700410570
VOLKSWAGEN	N10261506	VOLVO	30658983

* Non contractual information given as indication
