

1 Allée des Bouleaux -F-95110 SANNOIS
 +33 (0)1 39 98 55 00
 info@restagraf.com

MIDI-SICHERUNG 100A

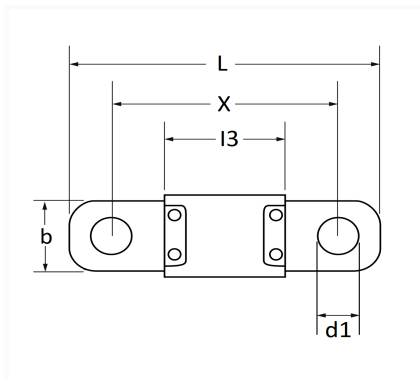

Item code	Number of References	Number of pieces	Conditioning
225084	1	1	BLISTER
17136	1	2	BEUTEL
317136	1	10	BEHÄLTER



Technical informations	
L	41 mm
b	10 mm
X	30 mm
d1	5.4 mm
l3	16 mm
Intens.	100 A

Materials
VERZINNTES KUPFER

Manufacturer correspondence*			
ALFA ROMEO	10404390	AUDI	N10525506

Manufacturer correspondence*			
B.M.W	61138364631	DS Automobiles	9665408480
FIAT	10404390	FORD Finis	1148217
FORD Werksnummer	2S6T14A094GA	HYUNDAI	1898005930
JAGUAR	C2C40191	JAGUAR	T2H36078
LAND ROVER	LR003746	LAND ROVER	LR080467
LAND ROVER	YQG100380L	MERCEDES-BENZ	N000000000415
MERCEDES-BENZ	N000000002801	MERCEDES-BENZ	N000000006628
MINI	61138364631	OPEL (GM) Katalognummer	6238740
OPEL (GM) Teilenummer	13133870	OPEL (GM) Teilenummer	95525689
OPEL (Stellantis)	9665408480	PEUGEOT / CITROËN	6500S2
PEUGEOT / CITROËN	9665408480	PORSCHE	99960707800
PORSCHE	99960709300	PORSCHE	N10839404
RENAULT	8200895550	VOLKSWAGEN	N10525506
VOLVO	9441940		

* Non contractual information given as indication