

**CACHE DE PROTECTION DROIT POUR BORNE ET COSSE DE BATTERIE
 MONTAGE FUSIBLE SERIE CF**

Code article	Nb de références	Nb de pièces	Conditionnement
217320	1	1	BOÎTE BROCHABLE

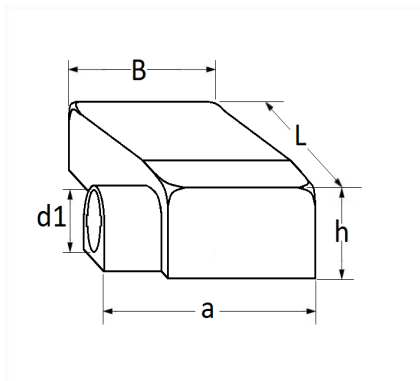

Informations techniques	
L	72 mm
B	37 mm
h	24 mm
a	55 mm
d1	16 mm

Matières

SILICONE

