

1 Allée des Bouleaux -F-95110 SANNOIS
 +33 (0)1 39 98 55 00
 info@restagraf.com

FUSIBLE J-CASE LOW PROFIL 58V 30A

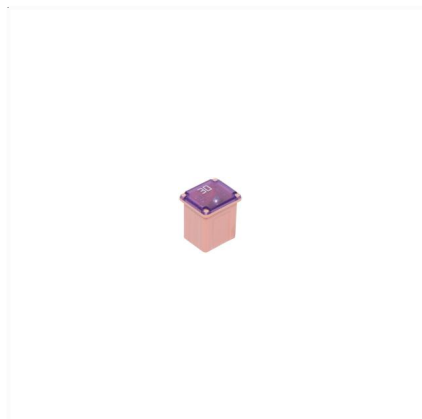

Code article	Nb de références	Nb de pièces	Conditionnement
17352	1	2	SACHET

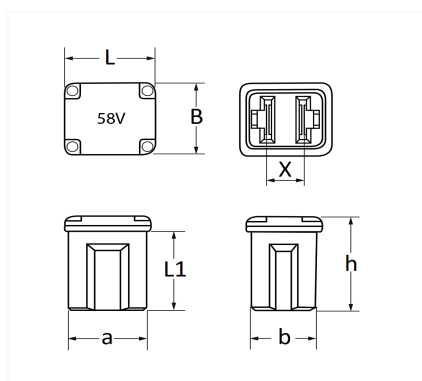

Informations techniques	
L	14.1 mm
B	12 mm
X	5.5 mm
h	15.9 mm
L1	13.6 mm
a	12.1 mm
b	10 mm
Intens.	30 A

Correspondances constructeurs*

ALFA ROMEO	11323490	CHEVROLET - DAEWOO	15485096
CHRYSLER - JEEP	11323490	CHRYSLER - JEEP	K68144443AA
CITROËN - PEUGEOT	6500Z3	CITROËN - PEUGEOT	6504A6
CITROËN - PEUGEOT	9666154780	DAIHATSU	9004940042
DAIHATSU	9004940042000	FIAT	71773500

Correspondances constructeurs*			
FIAT	K68144443AA	FORD Finis	4655703
FORD Finis	4780766	FORD N° Technique	6E5T14A094BA
FORD N° Technique	7T4T14A094CA	HONDA	38211SNAA11
HYUNDAI	1879001123	HYUNDAI	1879001129
ISUZU	8980791910	JAGUAR	C2S52414
JAGUAR	T2H36045	KIA	1879001123
KIA	1879001129	LANCIA	68137154AA
LAND ROVER	LR030045	LAND ROVER	LR075973
MAZDA	C24467S99	MERCEDES-BENZ	A4705401604
MITSUBISHI	MU000850	MITSUBISHI	MU001913
NISSAN	24370C993A	NISSAN	24370C993B
OPEL (GM) N° Catalogue	6238675	OPEL (GM) N° de Pièce	13257521
RENAULT	24370C994B	SUBARU	82211AJ30A
SUZUKI	0948130403	TESLA	105226130A
TOYOTA / LEXUS	9098208295	TOYOTA / LEXUS	9098208298
TOYOTA / LEXUS	9098208306	VOLVO	30728786

* Informations non contractuelles données à titre indicatif