



1 Allée des Bouleaux -F-95110 SANNOIS  
 +33 (0)1 39 98 55 00  
 info@restagraf.com

COIL OF 50 METERS ELECTRIC WIRE 1 mm<sup>2</sup> BROWN



Item code	Number of References	Number of pieces	Conditioning
16215	1	1	COIL

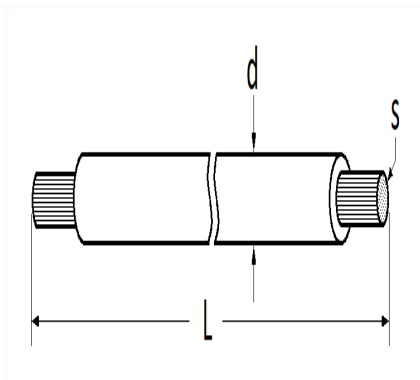

Technical informations	
L	50 m
d	2 mm
s	1 mm <sup>2</sup>

Materials
COPPER