

1 Allée des Bouleaux -F-95110 SANNOIS
 +33 (0)1 39 98 55 00
 info@restagraf.com

ÉCROU CAGE MÉTAL M6-1.00 AILE

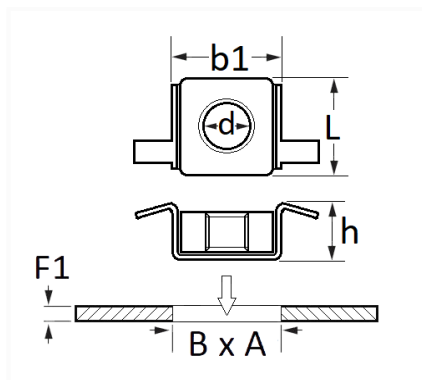

Code article	Nb de références	Nb de pièces	Conditionnement
10973	1	12	SACHET



Informations techniques	
L	35.7 mm
b1	20 mm
h	8.35 mm
d	M6 x 1.00
B	20 mm
A	20.2 mm
F1	2.5 mm

Matières

ACIER XC45

Correspondances constructeurs*

RENAULT 8200124827

* Informations non contractuelles données à titre indicatif