

1 Allée des Bouleaux -F-95110 SANNOIS
 +33 (0)1 39 98 55 00
 info@restagraf.com

RONDELLE CONTACT Ø 8 X 22 mm NF E25-511

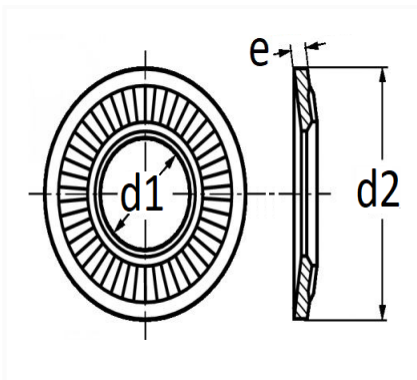

Code article	Nb de références	Nb de pièces	Conditionnement
863	1	25	SACHET
40360	1	100	BOÎTE



Informations techniques	
d1	8.2 mm
d2	22 mm
e	1.6 mm

Matières

ACIER XC68