

1 Allée des Bouleaux -F-95110 SANNOIS
 +33 (0)1 39 98 55 00
 info@restagraf.com

SORTIMENT SCHLAUCHSCHELLEN MIT SCHWENKKOPF Ø 25 → 110 mm L = 9 mm

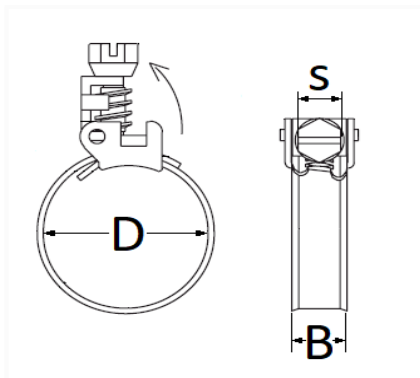

Item code	Number of References	Number of pieces	Conditioning
227561	5	5	BEUTEL



Technical informations	
D	25 → 110 mm
B	9 mm
s	7 mm

Materials
EDELSTAHL X6CR17 1.4016