

KONTAKTSCHIEBE Ø 6 X 14 mm NF E25-511

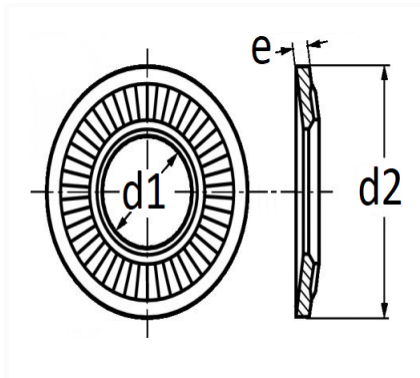

Item code	Number of References	Number of pieces	Conditioning
40355	1	200	BEHÄLTER
589	1	70	BEUTEL



Technical informations	
d1	6.1 mm
d2	14 mm
e	1.3 mm

Materials
STAHL XC68

Manufacturer correspondence*	
PEUGEOT / CITROËN	695716

\* Non contractual information given as indication