

**VIS À MÉTAUX TÊTE H CL10.9 M20-2.50 X 80 mm DIN 931 PARTIELLEMENT  
 FILETÉE**

Code article	Nb de références	Nb de pièces	Conditionnement
40166	1	6	BOÎTE

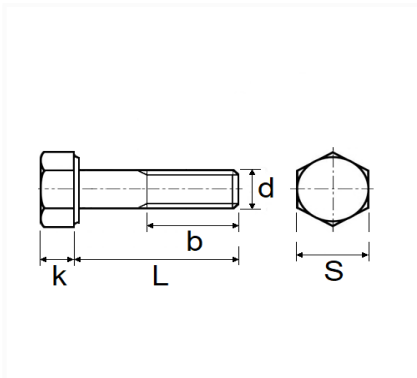

Informations techniques	
s	30 mm
k	12.5 mm
b	46 mm
L	80 mm
d	M20 x 2.50

**Matières**

ACIER CLASSE 10.9