

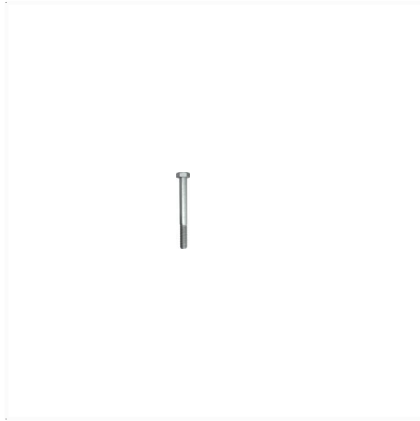

1 Allée des Bouleaux -F-95110 SANNOIS  
 +33 (0)1 39 98 55 00  
 info@restagraf.com

MASCHINENSCHRAUBE AUßENSECHSKANT 10.9 M14-2.00 X 130 mm DIN 93  
 TEILGEWINDE



Item code	Number of References	Number of pieces	Conditioning
40162	1	10	BEHÄLTER

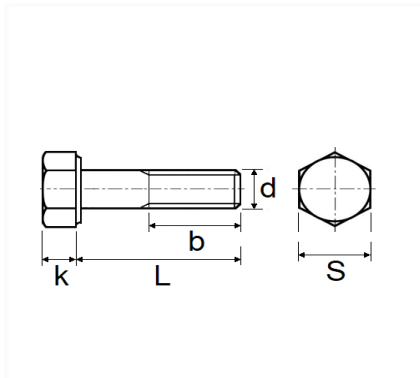

Technical informations	
s	22 mm
k	8.8 mm
b	40 mm
L	130 mm
d	M14 x 2.00

Materials
STAHL 10.9