

1 Allée des Bouleaux -F-95110 SANNOIS  
 +33 (0)1 39 98 55 00  
 info@restagraf.com

HEXAGON HEAD SELF TAPPING SCREW WITH WASHER Ø 4,2 X 20 mm

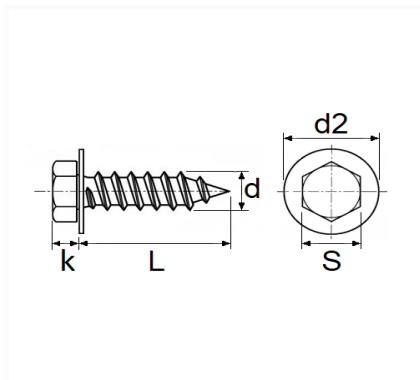

Item code	Number of References	Number of pieces	Conditioning
12945	1	12	BAG



Technical informations	
s	7 mm
k	4 mm
d2	17 mm
L	21 mm
d	4.2 mm

Manufacturer correspondence*			
FORD Engineering number	W716345S450B	FORD Finis	5197058
SUBSTITUTABLE FOR OPEL	11570498		

\* Non contractual information given as indication