

1 Allée des Bouleaux -F-95110 SANNOIS
 +33 (0)1 39 98 55 00
 info@restagraf.com

PLASTIC RIVET Ø 9 mm

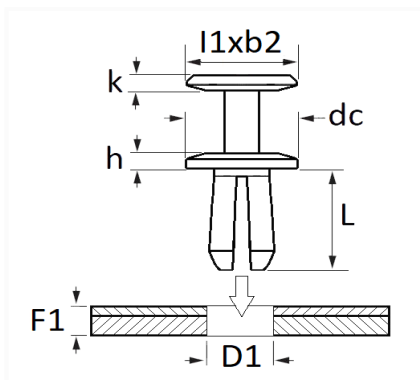

Item code	Number of References	Number of pieces	Conditioning
11960	1	8	BAG
42663	1	100	BOX
228175	1	4	BLISTER



Technical informations		
l1		15.3 mm
b2		10.8 mm
k		1.75 mm
dc		20 mm
h		2.75 mm
L		14 mm
D1		9 mm
F1		1 → 5 mm

Materials
POLYAMIDE 66

Manufacturer correspondence*			
MERCEDES-BENZ	A0009913940	SEAT	6J0853379

Manufacturer correspondence*

SKODA	6J0853379	VOLKSWAGEN	2E1857784
-------	-----------	------------	-----------

* Non contractual information given as indication
