

COLLIER À VIS TÊTE BASCULANTE Ø 25 → 40 mm L = 9 mm

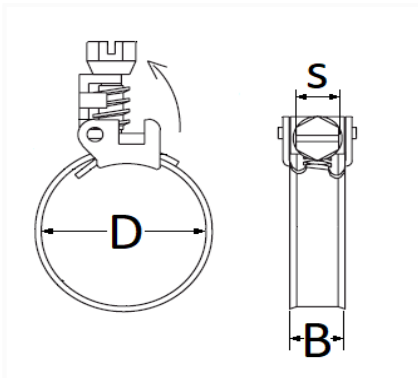

Code article	Nb de références	Nb de pièces	Conditionnement
7526	1	6	SACHET
227526	1	2	SACHET



Informations techniques	
D	25 → 40 mm
B	9 mm
s	7 mm

Matières
INOX X6Cr17 1.4016