

**SEGMENT D'ARRÊT Ø 20 X 1 mm DIN 472 INTÉRIEUR**

Code article	Nb de références	Nb de pièces	Conditionnement
7325	1	25	SACHET

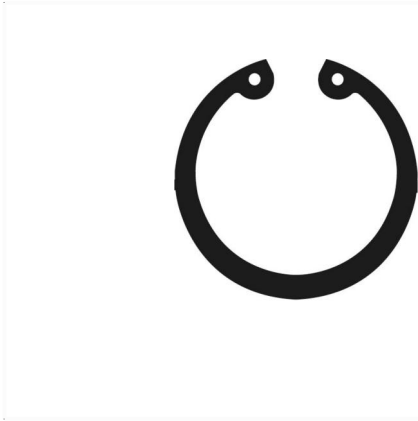
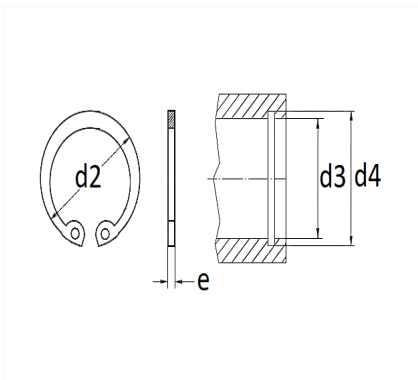

Informations techniques	
d3	20 mm
d2	21.5 mm
d4	21 mm
e	1 mm

**Matières**

ACIER XC75